

NATURAL SCIENCES  
ADMISSIONS ASSESSMENT

D568/11

2023

60 minutes

## SECTION 1

## INSTRUCTIONS TO CANDIDATES

Please read these instructions carefully, but do not open this question paper until you are told that you may do so. This paper is Section 1 of 2.

A separate answer sheet is provided for this paper. Please check you have one. You also require a soft pencil and an eraser.

Please complete the answer sheet with your candidate number, centre number, date of birth, and name.

At the end of 60 minutes, your supervisor will collect this question paper and answer sheet before giving out Section 2.

This paper contains **four** parts: **A, B, C** and **D**.

All candidates should complete **Part A** Mathematics.

All candidates should then complete **one** further part chosen from:

<b>Part B</b>	Physics
<b>Part C</b>	Chemistry
<b>Part D</b>	Biology

Each part has 20 multiple-choice questions. There are no penalties for incorrect responses, only marks for correct answers, so you should attempt all of the questions in your **two** parts. Each question is worth one mark.

For each question, choose the **one** option you consider correct and record your choice on the separate answer sheet. If you make a mistake, erase thoroughly and try again.

You **must** complete the answer sheet within the time limit.

You can use the question paper for rough working, but **no extra paper** is allowed. Only your responses on the answer sheet will be marked.

Dictionaries and calculators are NOT permitted.

**Please wait to be told you may begin before turning this page.**

*This question paper consists of 66 printed pages and 2 blank pages.*



**BLANK PAGE**

**Paper content**

PART A Mathematics .....	5
PART B Physics .....	17
PART C Chemistry .....	33
PART D Biology .....	48

**BLANK PAGE**

**PART A Mathematics**

- 1 The surface area of a solid sphere of radius  $R$  is equal to the total surface area of 10 solid closed cylinders of radius  $r$  and height  $4r$ .

Which of the following is an expression for  $R$  in terms of  $r$ ?

(The surface area of a sphere of radius  $R$  is  $4\pi R^2$ .)

- A  $R = 5r$
- B  $R = 12r$
- C  $R = 2\sqrt{5}r$
- D  $R = \frac{1}{2}\sqrt{10}r$
- E  $R = \sqrt{10}r$
- F  $R = \frac{3}{2}\sqrt{10}r$
- G  $R = \sqrt{15}r$

- 2 Which of the following statements is/are correct?

- 1  $\frac{47}{93} \div \frac{33}{71} = \frac{71}{93} \div \frac{33}{47}$
- 2 53% of 84 = 84% of 53
- 3  $(2\sqrt{3})^2 = (3\sqrt{2})^2$

- A none of them
- B 1 only
- C 2 only
- D 3 only
- E 1 and 2 only
- F 1 and 3 only
- G 2 and 3 only
- H 1, 2 and 3

- 3 Which of the following is a correct rearrangement of

$$y = p - \frac{q-r}{s-x}$$

to make  $x$  the subject?

**A**  $x = s - \frac{q-r}{p+y}$

**B**  $x = \frac{q-r}{p+y} - s$

**C**  $x = s - \frac{q-r}{p-y}$

**D**  $x = \frac{q-r}{p-y} - s$

**E**  $x = s - \frac{q-r}{y-p}$

**F**  $x = \frac{q-r}{y-p} - s$

- 4 Six numbers in increasing order are:

$$2, x, x, y, 23.5, 27.5$$

The mean of the six numbers is 12.

The median of the six numbers is 7.25.

What is the mode of the six numbers?

- A** 4.5  
**B** 4.75  
**C** 5  
**D** 9.625  
**E** 10  
**F** 11.75

5

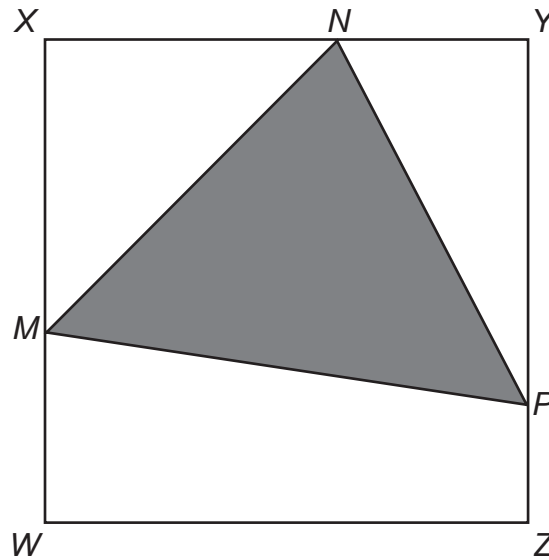

[diagram not to scale]

$WXYZ$  is a square of side length 1.

$$WM:MX = 1:2$$

$$XN:NY = 3:1$$

$$YP:PZ = 4:1$$

What is the area of triangle  $MNP$ ?

**A**  $\frac{1}{3}$

**B**  $\frac{2}{5}$

**C**  $\frac{9}{20}$

**D**  $\frac{1}{30}$

**E**  $\frac{19}{60}$

**F**  $\frac{23}{60}$



- 6 Which of the following is a simplification of

$$\frac{4x-8}{x^2+4x-12} \div \frac{x-6}{x^3-36x}$$

- A  $\frac{1}{4}$   
B  $\frac{1}{4x}$   
C 4  
D  $4x$   
E  $\frac{4x(x+6)}{(x-6)}$   
F  $\frac{4x(x-6)}{(x+6)}$   
G  $\frac{4}{x(x+6)^2}$   
H  $\frac{4}{x(x-6)^2}$

- 7 Given that

$$\frac{27^{2(x-2)}}{9^{(2x-3)}} = (81)^{\frac{3}{2}}$$

what is the value of  $x$ ?

- A 0  
B 2.5  
C 3  
D 6  
E 7.5  
F 9  
G 10.5  
H 12

- 8 The solutions of the equation  $3x^2 - 6x - 2 = 0$  are  $p$  and  $q$ , where  $p > q$ .

What is the value of  $3p + 2q$ ?

A  $-10 - \frac{2}{3}\sqrt{15}$

B  $-10 - \frac{2}{3}\sqrt{3}$

C  $-5 - \frac{1}{3}\sqrt{15}$

D  $-5 - \frac{1}{3}\sqrt{3}$

E  $5 + \frac{1}{3}\sqrt{15}$

F  $5 + \frac{1}{3}\sqrt{3}$

G  $10 + \frac{2}{3}\sqrt{15}$

H  $10 + \frac{2}{3}\sqrt{3}$

- 9 Last year, the salary of the coach of a football club was 80% of the salary of the star player.

At the start of the new year, the coach received a 15% increase in salary and the star player received a 38% increase in salary.

What percentage of the star player's new salary is the coach's new salary?

A 46%

B 57%

C  $61\frac{3}{5}\%$

D  $66\frac{2}{3}\%$

E 77%

F  $83\frac{1}{3}\%$

- 10 Two of the angles of a triangle are  $90^\circ$  and  $\theta$ , where

$$\tan \theta = \sqrt{2}$$

The length of the hypotenuse of the triangle is  $3\sqrt{6}$  cm.

What is the area of the triangle, in  $\text{cm}^2$ ?

- A  $\frac{9\sqrt{2}}{2}$   
B  $9\sqrt{2}$   
C  $9\sqrt{3}$   
D  $9\sqrt{6}$   
E  $18\sqrt{2}$   
F  $18\sqrt{3}$   
G  $18\sqrt{6}$
- 11 An athlete's training session consists of several complete repetitions of a three-part programme:
1. Walk 100 m at an average speed of  $6 \text{ km h}^{-1}$
  2. Jog 200 m at an average speed of  $10 \text{ km h}^{-1}$
  3. Run 100 m at an average speed of  $20 \text{ km h}^{-1}$

What is the athlete's average speed for the complete training session, in  $\text{km h}^{-1}$ ?

- A 7.2  
B 9.6  
C 11.5  
D 12  
E 14.4

- 12 The line joining the points with coordinates  $(q, 2 - q)$  and  $(2q + 2, q - 4)$  is perpendicular to the line with equation  $3x - 4y + 5 = 0$

What is the value of  $q$ ?

- A  $-\frac{2}{5}$
- B  $-\frac{1}{6}$
- C 1
- D  $\frac{18}{11}$
- E  $\frac{16}{7}$
- F  $\frac{5}{2}$
- G 6

- 13 Two objects X and Y are similar.

The surface area of object Y is double the surface area of object X.

The volume of object Y is  $7\sqrt{2} \text{ cm}^3$  more than the volume of object X.

What is the volume of object X, in  $\text{cm}^3$ ?

- A  $14 - 7\sqrt{2}$
- B  $14 + 7\sqrt{2}$
- C  $\frac{42 - 7\sqrt{2}}{17}$
- D  $\frac{42 + 7\sqrt{2}}{17}$
- E  $\frac{7\sqrt{2}}{3}$
- F  $7\sqrt{2}$
- G  $4 - \sqrt{2}$
- H  $4 + \sqrt{2}$

- 14  $x, y$  and  $z$  are positive variables.

$y$  is inversely proportional to the square of  $x$ .

When  $y = 20, x = 3$

$z$  is directly proportional to  $x$ .

When  $z = 1.2, x = 6$

What is  $z$  when  $y = 80$ ?

- A 0.0225  
B 0.03  
C 0.15  
D 0.3  
E 0.36  
F 0.6  
G 1.2
- 15 The equation

$$\left( \frac{a \times 10^4 + 2a \times 10^3}{3 \times 10^{-1}} \right)^2 = 8 \times 10^9$$

has two solutions for  $a$ .

What is the positive difference between these two solutions?

- A 0  
B  $2\sqrt{5}$   
C  $4\sqrt{5}$   
D  $20\sqrt{5}$   
E  $40\sqrt{5}$   
F  $200\sqrt{5}$

- 16 For any real number  $x$ , the function  $V(x)$  is defined as:

$$V(x) = 10^{x^2+6x+7}$$

What is the smallest value of  $V(x)$ ?

- A 0.001
  - B 0.01
  - C 0.1
  - D 1
  - E 10
  - F 100
  - G 1000
- 17  $X$  and  $Y$  are the end-points of a line segment.

Point  $P$  has coordinates  $(-8, 5)$ .

$P$  lies on the line segment  $XY$  such that  $XP:PY$  is  $1:2$  and  $\overrightarrow{XP} = \begin{pmatrix} 4 \\ -3 \end{pmatrix}$

A point  $Q$  is such that  $\overrightarrow{QY} = \begin{pmatrix} 7 \\ 6 \end{pmatrix}$

What are the coordinates of point  $Q$ ?

- A  $(7, 5)$
- B  $(3, 8)$
- C  $(1, -12)$
- D  $(-3, -10)$
- E  $(-7, -7)$
- F  $(-11, -4)$

- 18 The 2<sup>nd</sup> term of a linear (arithmetic) sequence is equal to twice the 8<sup>th</sup> term.

The 5<sup>th</sup> term is  $\frac{9}{4}$

What is the 20<sup>th</sup> term of the sequence?

- A -9
- B  $-\frac{7}{4}$
- C  $-\frac{3}{2}$
- D 6
- E  $\frac{31}{4}$
- F  $\frac{27}{2}$

- 19 Find the maximum value of

$$2^{\sin x} \times 3^{-\sin x}$$

where  $0^\circ \leq x \leq 360^\circ$

- A  $\frac{2}{3}$
- B 1
- C  $\frac{3}{2}$
- D 2
- E 3
- F 6

**20** Two bags contain counters which are identical except for colour.

The first bag contains 3 blue and 2 yellow counters.

The second bag contains  $x$  red, 1 blue and 2 yellow counters.

A counter is picked at random from the first bag and placed in the second bag.

A counter is then picked at random from the second bag. The probability that this counter is yellow is 0.2. What is the probability that this counter is red?

**A**  $\frac{1}{4}$

**B**  $\frac{3}{11}$

**C**  $\frac{3}{10}$

**D**  $\frac{1}{3}$

**E**  $\frac{2}{3}$

**F**  $\frac{7}{10}$

**G**  $\frac{8}{11}$

**H**  $\frac{3}{4}$



**PART B Physics**

- 21 An object has mass  $m$  and weight  $W$  on the Moon. The Moon has no atmosphere.

The object is released from rest at height  $h$  above the surface of the Moon.

Which expression gives the speed of the object as it reaches the surface?

- A  $\frac{Wh}{m}$
- B  $\frac{2Wh}{m}$
- C  $\frac{2mh}{W}$
- D  $2mWh$
- E  $\sqrt{2mWh}$
- F  $\sqrt{\frac{Wh}{m}}$
- G  $\sqrt{\frac{2Wh}{m}}$
- H  $\sqrt{\frac{2mh}{W}}$

- 22 A spaceship of mass 10 000 kg is moving at  $2.0 \text{ m s}^{-1}$  relative to a space station.

The spaceship is captured by a robotic arm attached to the space station and brought to rest by a force of 1000 N.

How far will the spaceship move in its initial direction relative to the space station while the force is being applied?

(Assume that the acceleration of the space station is negligible.)

- A 0.050 m
- B 0.10 m
- C 0.20 m
- D 5.0 m
- E 10 m
- F 20 m

- 23 A heater is connected in series with a dc power supply, a variable resistor and an ammeter in the circuit shown.

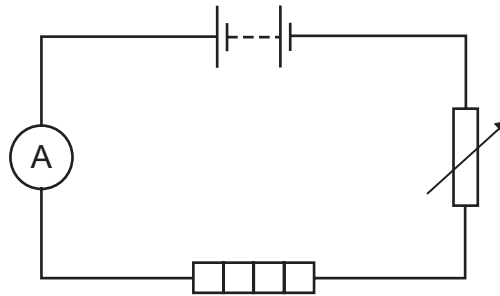

The variable resistor is adjusted until the reading on the ammeter is 0.50 A and the resistance of the heater is  $8.0\ \Omega$ .

How much energy is converted to thermal energy in 5.0 minutes?

- A 10 J
- B 40 J
- C 160 J
- D 600 J
- E 2400 J
- F 9600 J

24 A circuit is set up as shown. All three resistors are identical.

When the switch is open, the reading on the ammeter is 1.0 A and the power transferred from the battery is 1.0 W.

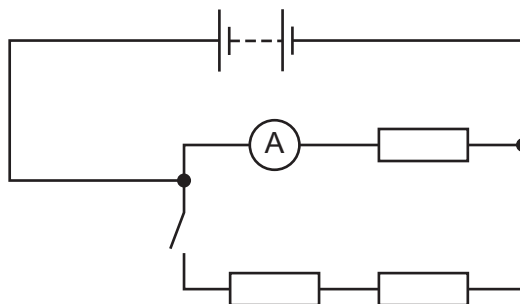

The switch is now closed.

What is the new reading on the ammeter and what is the new power transferred from the battery?

	<i>ammeter reading / A</i>	<i>power transferred / W</i>
<b>A</b>	0.67	0.67
<b>B</b>	0.67	1.3
<b>C</b>	0.67	1.5
<b>D</b>	0.67	2.0
<b>E</b>	1.0	1.0
<b>F</b>	1.0	1.5
<b>G</b>	1.0	2.0
<b>H</b>	1.0	3.0

- 25** A car travels for a total time of 20 s. For the first  $t$  seconds its speed is  $5.0 \text{ m s}^{-1}$  and for the remainder of the journey its speed is  $10 \text{ m s}^{-1}$ .

The average speed for the whole journey is  $8.5 \text{ m s}^{-1}$ .

What is the value of  $t$ ?

- A** 3.0
- B** 6.0
- C** 10
- D** 17
- E**  $\frac{20}{3}$
- F**  $\frac{40}{3}$

- 26** A spring is initially unstretched. A force  $F$  is used to stretch the spring. The extension  $x$  and the energy  $E$  stored in the stretched spring are measured for different values of  $F$ .

The graph shows how the energy  $E$ , in J, varies with the extension squared,  $x^2$ , in  $\text{cm}^2$ .

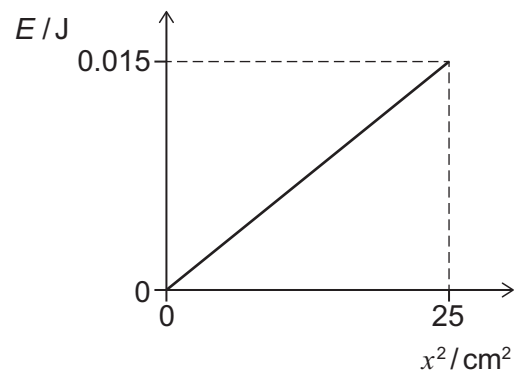

What is the magnitude of  $F$  when the spring stores 0.015 J of energy?

- A** 0.30 N
- B** 0.60 N
- C** 1.2 N
- D** 1.5 N
- E** 2.4 N
- F** 3.0 N
- G** 30 N
- H** 60 N

- 27 The nuclide symbol for helium-3 is  ${}^3_2\text{He}$ .

A nuclide of element X has double the nuclear charge and four times the mass of helium-3.

This nuclide of X decays by a single beta ( $\beta^-$ ) emission to form a nuclide of element Z.

What is the nuclide symbol for this nuclide of Z?

- A  ${}^8_2\text{Z}$
- B  ${}^8_4\text{Z}$
- C  ${}^{12}_4\text{Z}$
- D  ${}^8_5\text{Z}$
- E  ${}^{12}_5\text{Z}$
- F  ${}^{16}_5\text{Z}$
- G  ${}^7_8\text{Z}$
- H  ${}^{16}_8\text{Z}$

- 28 A solid, cylindrical metal bar has a uniform cross-sectional area of  $12\text{ cm}^2$  and a volume of  $180\text{ cm}^3$ .

The bar rests on a horizontal surface on one of its circular faces.

The pressure on the surface due to the bar is  $0.45\text{ N cm}^{-2}$ .

What is the density of the metal, in  $\text{g cm}^{-3}$ ?

(gravitational field strength =  $10\text{ N kg}^{-1}$ )

- A  $2.5\text{ g cm}^{-3}$
- B  $3.0\text{ g cm}^{-3}$
- C  $3.75\text{ g cm}^{-3}$
- D  $7.5\text{ g cm}^{-3}$
- E  $15\text{ g cm}^{-3}$
- F  $33\text{ g cm}^{-3}$

- 29 A ray of light is directed horizontally towards two long, plane mirrors X and Y which are both at  $45^\circ$  to the horizontal. After two reflections the ray is travelling horizontally again.

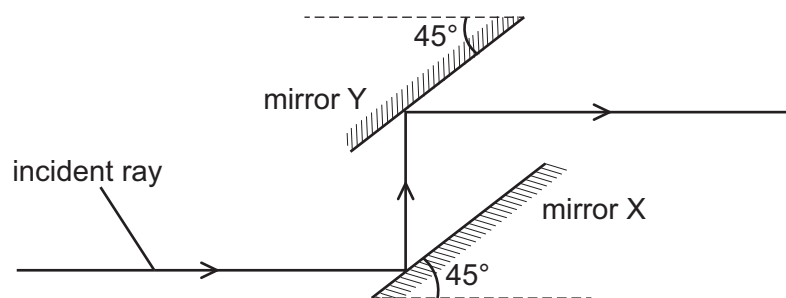

Mirror X is now rotated clockwise through less than  $45^\circ$ . After this rotation, mirror X makes an angle  $\theta$  with the horizontal, where  $\theta < 45^\circ$ . The direction of the incident ray is unchanged.

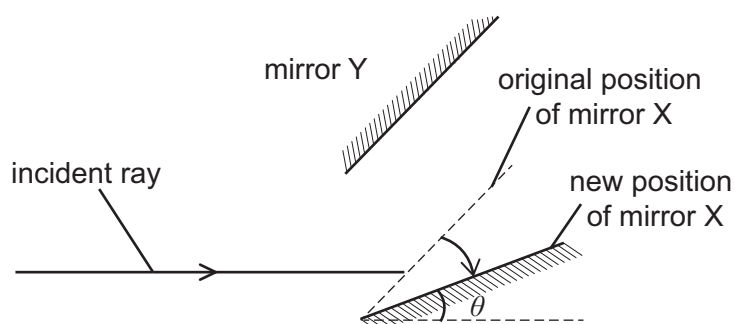

In what direction and through what angle should mirror Y be rotated in order for the ray to be still horizontal and travelling to the right after reflecting from mirror Y?

- A clockwise through an angle  $\theta$
- B anticlockwise through an angle  $\theta$
- C clockwise through an angle  $2\theta$
- D anticlockwise through an angle  $2\theta$
- E clockwise through an angle  $45^\circ - \theta$
- F anticlockwise through an angle  $45^\circ - \theta$



- 30** Two samples of pure radioactive isotopes X and Y decay with half-lives of 2 days and 3 days, respectively.

Both X and Y decay in a single step into different stable isotopes.

Initially the number of atoms of X is twice the number of atoms of Y.

After how many days are the expected numbers of atoms of X and Y equal to each other?

- A** The expected numbers of atoms of X and Y are never equal.
- B** 2 days
- C** 3 days
- D** 4 days
- E** 6 days
- F** 12 days

31 Two stones are held at rest at the same height at the top of a cliff.

One stone is released and falls freely under gravity.

A time  $T$  later, the other stone is released and falls freely under gravity.

Which graph shows how the vertical distance separating the stones varies with time, from the moment the first stone is released and before the first stone lands?

(Assume that air resistance is negligible.)

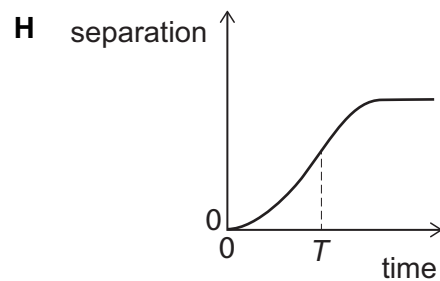
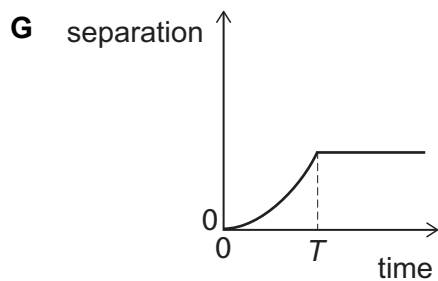
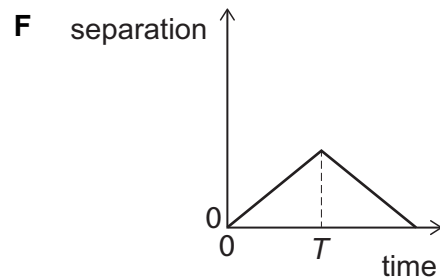
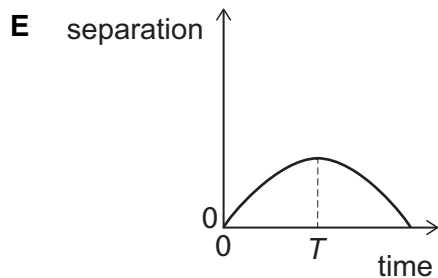
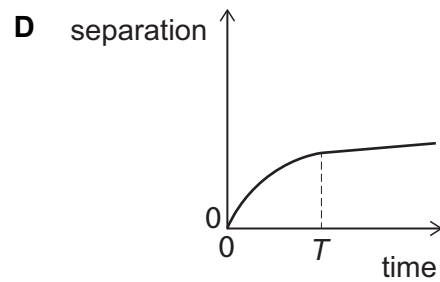
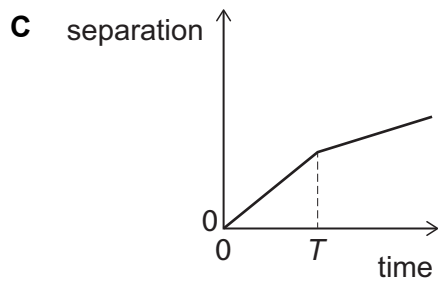
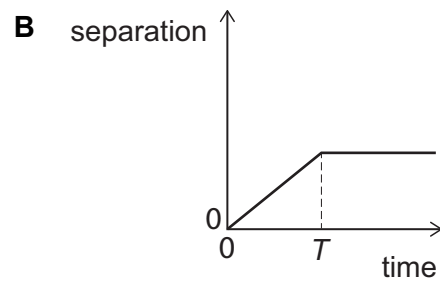
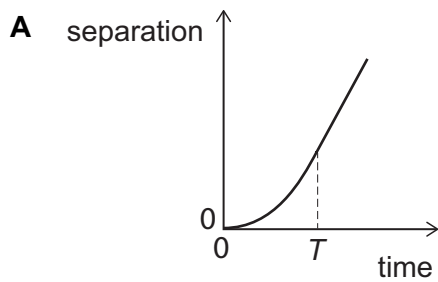

- 32** A large, flat, metal plate is coated on one side with a layer of thermally insulating material of the same thickness  $a$  as the metal plate.

The uninsulated top surface of the metal plate is maintained at a constant temperature  $T_1$ .

The bottom surface of the insulating material is maintained at a constant, lower temperature  $T_2$ .

The system is in equilibrium.

The diagram shows this arrangement.

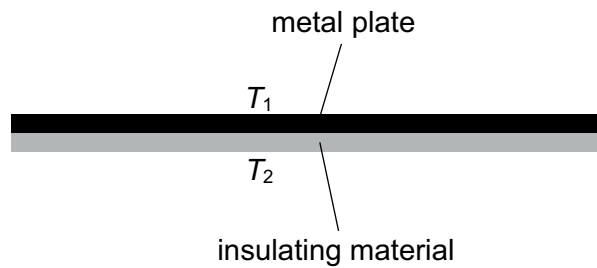

Which graph could show how the temperature varies with distance from the top surface of the metal plate to the bottom surface of the insulating material?

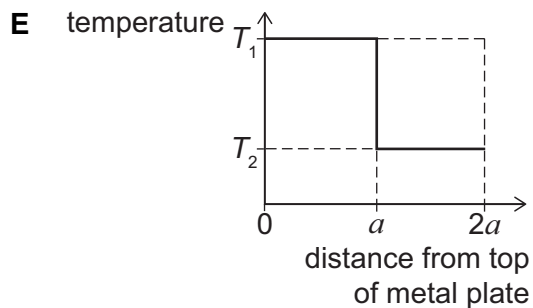
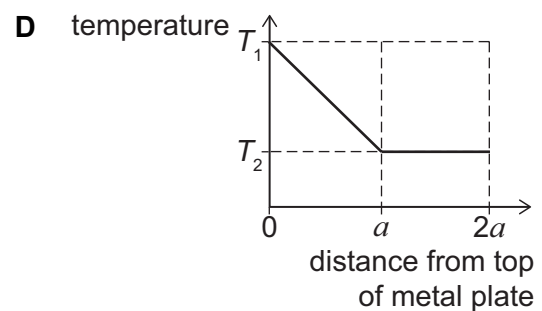
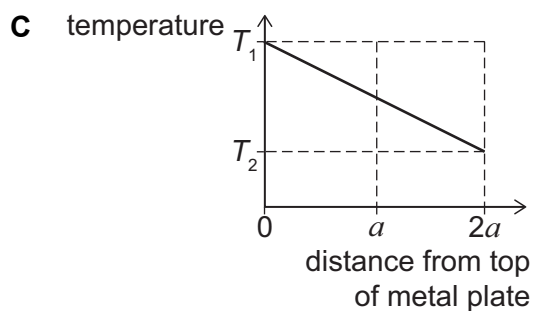
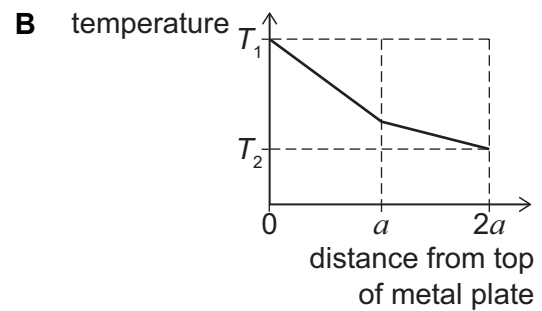
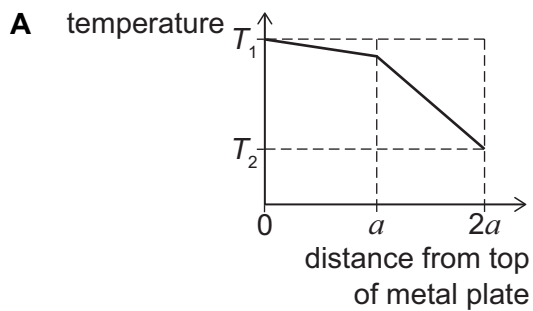

- 33** 10g of ice at  $0^\circ\text{C}$  is added to 20g of liquid water at  $30^\circ\text{C}$ .

The mixture reaches thermal equilibrium.

What is its equilibrium temperature,  $T$ ?

(specific latent heat of fusion of ice =  $330\text{ Jg}^{-1}$   
specific heat capacity of liquid water =  $4.2\text{ Jg}^{-1}\text{ }^\circ\text{C}^{-1}$

assume that there is no heat transfer between the mixture and its surroundings)

- A**  $T < 0^\circ\text{C}$
  - B**  $T = 0^\circ\text{C}$
  - C**  $0^\circ\text{C} < T < 20^\circ\text{C}$
  - D**  $T = 20^\circ\text{C}$
  - E**  $20^\circ\text{C} < T < 30^\circ\text{C}$
  - F**  $T = 30^\circ\text{C}$
  - G**  $T > 30^\circ\text{C}$
- 34** The voltage output of a power station is stepped up using a transformer before the power is transmitted to a distant town. The primary coil of this transformer has 300 turns and the secondary coil has 1500 turns.

In the town, a step-down transformer reduces the voltage supplied by the transmission cables to  $33\,000\text{ V}$  for distribution within the town. The step-down transformer supplies a current of  $1500\text{ A}$ .

The current in the transmission cables is  $450\text{ A}$  and both transformers are ideal and 100% efficient.

What is the voltage output of the power station?

(Assume that the resistance of the transmission cables is negligible.)

- A**  $1980\text{ V}$
- B**  $6600\text{ V}$
- C**  $22\,000\text{ V}$
- D**  $110\,000\text{ V}$
- E**  $550\,000\text{ V}$

- 35** A physicist introduces a thin piece of glass into the path of a laser beam in order to delay the beam. The light of the laser beam has a single wavelength  $L$  in air.

While the beam is inside the glass it completes 10 more complete oscillations compared to the same beam passing through the same thickness of air.

The speed of light in air is  $c$  and the speed of light in glass is  $\frac{2}{3}c$

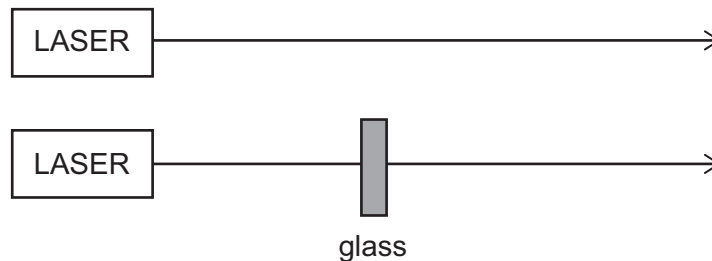

What is the thickness of the glass?

- A**  $6.7L$
- B**  $10L$
- C**  $13L$
- D**  $15L$
- E**  $20L$
- F**  $30L$
- 36** A transverse wave with an amplitude of 3.0 cm travels along a stretched string. The wave has a frequency of 12 Hz and a wavelength of 0.25 m.

What is the average speed of a particle in the string as the string oscillates during a time of 2.0 s?

- A**  $36 \text{ cm s}^{-1}$
- B**  $72 \text{ cm s}^{-1}$
- C**  $125 \text{ cm s}^{-1}$
- D**  $144 \text{ cm s}^{-1}$
- E**  $300 \text{ cm s}^{-1}$

- 37 A copper ring, with a small gap XY, rests in a uniform horizontal magnetic field. The ring lies in the plane of the page and the direction of the magnetic field is horizontal from left to right, as shown in the diagram.

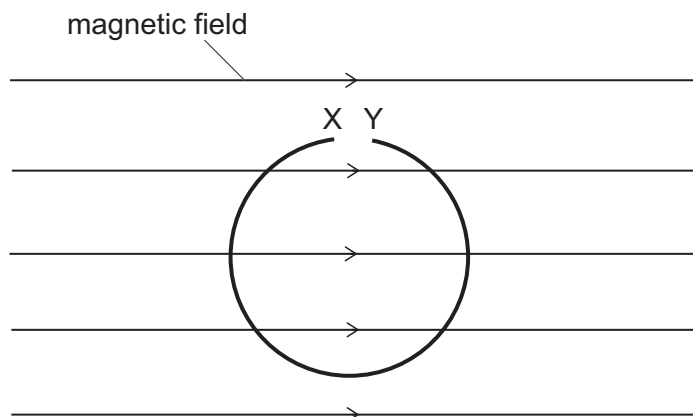

A voltage is now applied across XY, such that X is connected to the positive terminal of the power supply and Y is connected to the negative terminal.

Which statement describes the motion of the ring immediately after the voltage is applied?

(Assume that the mechanism supporting the ring allows the ring to move freely and allows the voltage to be applied continuously.)

- A The ring moves towards the bottom of the page.
- B The ring moves towards the top of the page.
- C The ring moves towards the left of the page.
- D The ring moves towards the right of the page.
- E The ring rotates about an axis perpendicular to the plane of the page in a clockwise direction.
- F The ring rotates about an axis perpendicular to the plane of the page in an anti-clockwise direction.
- G The ring rotates about an axis that is in the plane of the page and parallel to the field.
- H The ring rotates about an axis that is in the plane of the page and perpendicular to the field.

- 38 A battery and two resistors X and Y are connected in series.

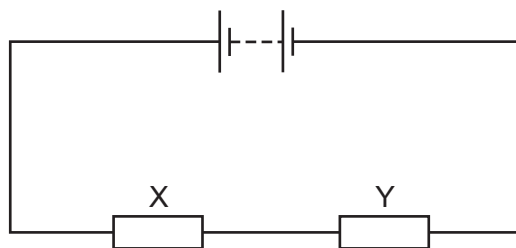

The power transferred by the battery is 6 W.

The resistance of X is  $10\ \Omega$ .

The voltage across Y is 4 V.

What is the current in the circuit?

- A  $\frac{2}{5}\ \text{A}$
- B  $\frac{3}{5}\ \text{A}$
- C  $\frac{3}{4}\ \text{A}$
- D 1 A
- E  $\sqrt{\frac{3}{10}}\ \text{A}$
- F  $\sqrt{\frac{3}{5}}\ \text{A}$

- 39** A cubic block of wood of side length  $L$  floats in water with the top face of the block horizontal and above the surface.
- The block is displaced downwards by a small distance  $\frac{L}{10}$  without becoming fully submerged, and then released.
- The density of the wood is  $0.80 \text{ g cm}^{-3}$  and the density of water is  $1.0 \text{ g cm}^{-3}$ .
- What is the initial acceleration of the block after it is released?
- (gravitational field strength =  $10 \text{ N kg}^{-1}$ )
- A**  $0.80 \text{ ms}^{-2}$
  - B**  $1.0 \text{ ms}^{-2}$
  - C**  $1.25 \text{ ms}^{-2}$
  - D**  $1.80 \text{ ms}^{-2}$
  - E**  $8.0 \text{ ms}^{-2}$
  - F**  $11.0 \text{ ms}^{-2}$
- 40** A diver at the bottom of a lake of depth  $d$  fills a syringe with an ideal gas and seals the nozzle. The piston remains free to move. The volume of the gas in the syringe at the bottom of the lake is  $90 \text{ cm}^3$ .
- As the diver returns to the surface, the temperature of the gas does not change. At the surface of the lake the gas in the syringe is at atmospheric pressure and the volume of the gas is  $720 \text{ cm}^3$ .
- What is the volume of the gas in the syringe at a depth  $\frac{d}{2}$  ?
- A**  $160 \text{ cm}^3$
  - B**  $180 \text{ cm}^3$
  - C**  $206 \text{ cm}^3$
  - D**  $225 \text{ cm}^3$
  - E**  $288 \text{ cm}^3$
  - F**  $315 \text{ cm}^3$
  - G**  $360 \text{ cm}^3$
  - H**  $405 \text{ cm}^3$



**PART C Chemistry**

- 41 An experiment is carried out at two different pressures by changing the volume of the reaction vessel.

The experiment measures the rate of the reaction between molecules X and Y to form Z:

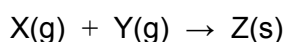

Assume that the experiments are carried out under exactly the same conditions apart from the difference in pressure.

How will the rate of the reaction change with pressure, if at all, and what is the reason for this?

	<i>difference in rate of reaction</i>	<i>reason</i>
<b>A</b>	the reaction is faster at lower pressure	average kinetic energy of molecules is greater at lower pressure
<b>B</b>	the reaction is faster at lower pressure	the rate of collisions is greater between molecules at lower pressure
<b>C</b>	the reaction is slower at lower pressure	average kinetic energy of molecules is less at lower pressure
<b>D</b>	the reaction is slower at lower pressure	the rate of collisions between molecules is lower at lower pressure
<b>E</b>	the reaction rate is the same at both pressures	the average kinetic energy of molecules is the same at both pressures

- 42 Which of the following represents the structure of the addition polymer formed from but-1-ene?

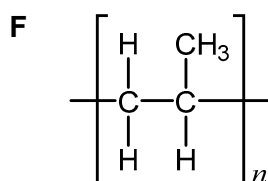
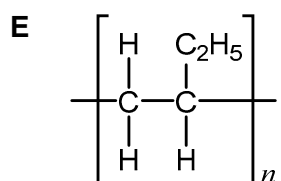
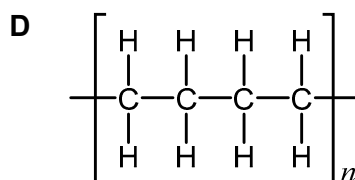
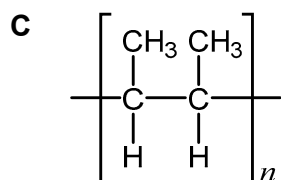
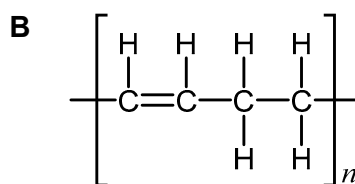
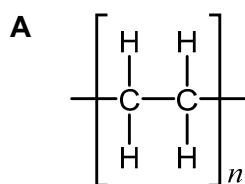

- 43 The chart shows the relative abundances of the isotopes of an element.

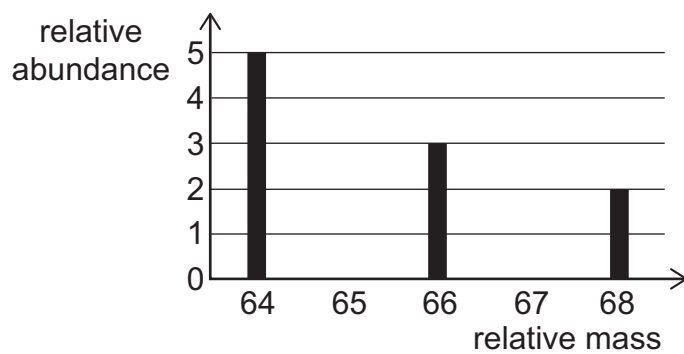

What is the relative atomic mass ( $A_r$ ) of this element?

- A 64.0
- B 65.4
- C 65.8
- D 66.0
- E 66.6

**44** In this question, all solutions have the same concentration in  $\text{mol dm}^{-3}$ .

Three separate experiments were set up using the same volume of each solution:

experiment 1:  $\text{LiCl(aq)}$  and  $\text{AgNO}_3\text{(aq)}$

experiment 2:  $\text{NaCl(aq)}$  and  $\text{AgNO}_3\text{(aq)}$

experiment 3:  $\text{KCl(aq)}$  and  $\text{AgNO}_3\text{(aq)}$

For each experiment, the solid formed was filtered, washed, dried, and weighed.

Which of the following statements is/are correct?

- 1 Experiment 3 forms the greatest mass of solid.
- 2 Experiment 3 has a noticeably greater rate of reaction than the others.
- 3 The reaction taking place in each experiment is a redox reaction.

**A** none of them

**B** 1 only

**C** 2 only

**D** 3 only

**E** 1 and 2 only

**F** 1 and 3 only

**G** 2 and 3 only

**H** 1, 2 and 3

**45** How many moles of ions are present in  $20 \text{ cm}^3$  of  $0.15 \text{ mol dm}^{-3}$  magnesium nitrate solution?

(Ignore ions produced by dissociation of water.)

**A** 0.003 mol

**B** 0.006 mol

**C** 0.009 mol

**D** 0.018 mol

**E** 0.133 mol

**F** 0.400 mol

- 46 Silicon is directly below carbon in the Periodic Table and has a melting point of 1414 °C.

Which of the following statements explains why silicon has a high melting point?

- A It forms ions with a charge of 4+.
- B Its structure is a giant ionic lattice.
- C It has a strong attraction between positive nuclei and delocalised electrons.
- D It has strong intermolecular forces.
- E Covalent bonds are broken on melting.
- 47 Atoms of element Q have two full shells of electrons and the third shell requires one more electron to gain a noble gas configuration.

Which row of the table correctly describes the elements near to Q in the Periodic Table?

	<i>element immediately above Q</i>	<i>element immediately below Q</i>	<i>element immediately to the left of Q</i>	<i>element immediately to the right of Q</i>
<b>A</b>	requires one more electron to fill a second shell of electrons	gains an electron less favourably than Q	the atom contains one fewer proton than Q	is very unreactive compared to Q
<b>B</b>	gains an electron more favourably than Q	the atom contains more protons than Q	is found in Period 3	is a halogen
<b>C</b>	requires one more electron to fill a second shell of electrons	gains an electron less favourably than Q	is an alkaline earth metal	the atom contains one more proton than Q
<b>D</b>	is found in Period 3	contains an extra full shell of electrons compared to Q	the atom contains one fewer proton than Q	is very unreactive compared to Q
<b>E</b>	gains an electron more favourably than Q	the atom contains more protons than Q	the atom has an atomic number greater than Q	is found in Period 3

- 48 A simple ion of an element has a mass number  $x$ , an atomic number  $\frac{x-1}{2}$  and a charge of  $-1$ .

How many protons, neutrons and electrons are present in this ion?

	<i>protons</i>	<i>neutrons</i>	<i>electrons</i>
<b>A</b>	$\frac{x-1}{2}$	$\frac{x-1}{2}$	$\frac{x-1}{2}$
<b>B</b>	$\frac{x-1}{2}$	$\frac{x+1}{2}$	$\frac{x+1}{2}$
<b>C</b>	$\frac{x-1}{2}$	$\frac{x+1}{2}$	$\frac{x-1}{2}$
<b>D</b>	$\frac{x-1}{2}$	$\frac{x-1}{2}$	$\frac{x+1}{2}$
<b>E</b>	$\frac{x+1}{2}$	$\frac{x-1}{2}$	$\frac{x+1}{2}$
<b>F</b>	$\frac{x+1}{2}$	$\frac{x-1}{2}$	$\frac{x-1}{2}$

- 49 Titanium metal can be extracted from titanium(IV) chloride,  $\text{TiCl}_4$ .

Titanium(IV) chloride is heated to  $1000^\circ\text{C}$  with either sodium or magnesium metal in an atmosphere of argon.

Which one of the following statements is correct?

( $A_r$  values: Na = 23; Mg = 24; Cl = 35.5; Ti = 48)

- A** A greater mass of magnesium chloride than sodium chloride is produced for each tonne of titanium made.
- B** The atmosphere of argon is used as a catalyst.
- C** In each reaction equation, the ratio of the reacting metal to titanium(IV) chloride is the same.
- D** Titanium is a weaker oxidising agent than either sodium or magnesium.
- E** A smaller mass of magnesium than sodium is required to produce 500 kg of titanium.

- 50** Ethene gas and hydrogen gas react to form ethane gas.

The energy change for this reaction is  $-150 \text{ kJ mol}^{-1}$ .

Using the provided data, what is the mean C–H bond energy?

(Bond energy data:  $\text{H–H} = 430 \text{ kJ mol}^{-1}$ ;  $\text{C–C} = 350 \text{ kJ mol}^{-1}$ ;  $\text{C=C} = 600 \text{ kJ mol}^{-1}$ )

- A**  $115 \text{ kJ mol}^{-1}$
  - B**  $200 \text{ kJ mol}^{-1}$
  - C**  $230 \text{ kJ mol}^{-1}$
  - D**  $265 \text{ kJ mol}^{-1}$
  - E**  $400 \text{ kJ mol}^{-1}$
  - F**  $415 \text{ kJ mol}^{-1}$
  - G**  $465 \text{ kJ mol}^{-1}$
  - H**  $830 \text{ kJ mol}^{-1}$
- 51** A water treatment unit processes  $355\,000 \text{ dm}^3$  of drinking water each day.

$0.4 \text{ mg}$  of chlorine gas is used to kill the bacteria in  $1 \text{ dm}^3$  of the source water.

What volume of chlorine gas, if measured at room temperature and pressure, is used each day at the water treatment unit?

( $A_r$  value:  $\text{Cl} = 35.5$ . Assume that one mole of a gas occupies  $24 \text{ dm}^3$  at room temperature and pressure.)

- A**  $6 \text{ dm}^3$
- B**  $12 \text{ dm}^3$
- C**  $48 \text{ dm}^3$
- D**  $96 \text{ dm}^3$
- E**  $300 \text{ dm}^3$
- F**  $600 \text{ dm}^3$

- 52** Element X is in Group 13, Period 4. It consists of atoms of two isotopes with mass numbers 69 and 71. The relative atomic mass of element X is 69.7.

Which of the following statements is/are correct about element X?

- 1** 75% of the atoms of element X have mass number 69.
  - 2** An atom of element X has three electrons in its outer shell.
  - 3** Element X forms an oxide with formula  $X_2O_3$  that reacts with acids.
- 
- A** none of them
  - B** 1 only
  - C** 2 only
  - D** 3 only
  - E** 1 and 2 only
  - F** 1 and 3 only
  - G** 2 and 3 only
  - H** 1, 2 and 3



**53** One mole of copper reacts completely with an excess of concentrated nitric acid.

A gaseous oxide of nitrogen is one of the products of the reaction. The volume of this gas is  $48 \text{ dm}^3$  when measured at room temperature and pressure.

The oxidation state of the nitrogen in the gaseous oxide is one less than the oxidation state of the nitrogen in the nitric acid.

Which of the following could be the equation for this reaction?

(Assume that one mole of any gas occupies  $24 \text{ dm}^3$  at room temperature and pressure.)

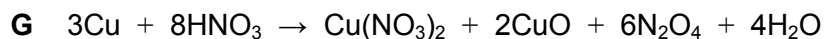
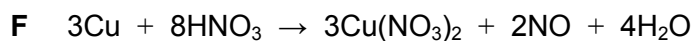
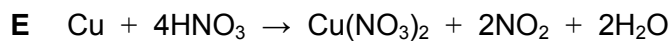
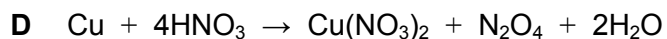
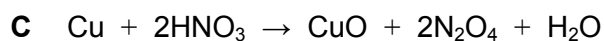
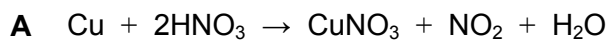

- 54** Two experiments were carried out using separate samples of a solution of an acid of concentration  $0.40 \text{ mol dm}^{-3}$  ( $36 \text{ g dm}^{-3}$ ) and the following observations were made.
- $25 \text{ cm}^3$  of the acid solution exactly neutralised  $100 \text{ cm}^3$  of  $0.20 \text{ mol dm}^{-3}$  sodium hydroxide solution.
  - Bubbles of gas were given off when magnesium ribbon was added to the acid solution.

Which of the following statements can be deduced from this information?

- 1** It is a monoprotic acid.
  - 2** It is a strong acid.
  - 3** The acid has a relative molar mass ( $M_r$ ) of 90.
- A** none of them
- B** 1 only
- C** 2 only
- D** 3 only
- E** 1 and 2 only
- F** 1 and 3 only
- G** 2 and 3 only
- H** 1, 2 and 3

- 55 When methanol is burned in the apparatus shown it gives out  $720 \text{ kJ mol}^{-1}$ . However, only 80% of the energy released is transferred into the water.

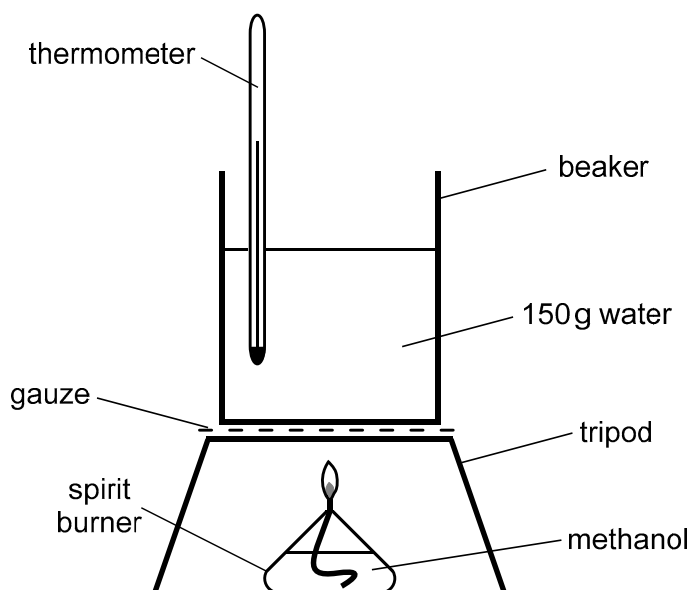

The starting temperature of the water is  $12^\circ\text{C}$ .

What mass of methanol would need to be burned to give a  $60^\circ\text{C}$  temperature rise in the water?

( $M_r$  value: methanol = 32. Assume that the specific heat capacity of water =  $4 \text{ J g}^{-1} \text{ }^\circ\text{C}^{-1}$ )

- A 1.28 g
- B 1.60 g
- C 1.92 g
- D 2.00 g
- E 2.40 g

- 56** A student electroplates a solid metal ball with copper.

The student dissolves 80.0 g of anhydrous copper(II) sulfate in water and makes up the solution to exactly 500 cm<sup>3</sup> to use as the electrolyte.

Two electrodes are placed in this solution. One electrode is the ball to be electroplated and the other electrode is an inert graphite electrode. The electrodes are connected to a battery.

After some time, the ball is removed and is found to be coated with 8.00 g of copper. Water is added to the remaining solution to give a final volume of exactly 500 cm<sup>3</sup>.

What is the final concentration of the copper(II) ions in solution?

( $A_r$  values: O = 16; S = 32; Cu = 64)

- A** 0.25 mol dm<sup>-3</sup>
- B** 0.38 mol dm<sup>-3</sup>
- C** 0.45 mol dm<sup>-3</sup>
- D** 0.50 mol dm<sup>-3</sup>
- E** 0.75 mol dm<sup>-3</sup>
- F** 0.90 mol dm<sup>-3</sup>
- G** 1.0 mol dm<sup>-3</sup>

57 The structure of cyclohexa-1,4-diene is:

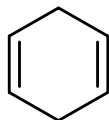

Bromine is dissolved in inert organic solvent to form  $0.250 \text{ mol dm}^{-3}$  of bromine solution.

What is the minimum volume of this bromine solution required to react completely with  $0.10 \text{ cm}^3$  of cyclohexa-1,4-diene?

( $M_r$  value: cyclohexa-1,4-diene = 80. Density of cyclohexa-1,4-diene =  $0.84 \text{ g cm}^{-3}$ )

- A  $0.042 \text{ cm}^3$
- B  $0.084 \text{ cm}^3$
- C  $0.0042 \text{ cm}^3$
- D  $0.0084 \text{ cm}^3$
- E  $0.042 \text{ dm}^3$
- F  $0.084 \text{ dm}^3$
- G  $0.0042 \text{ dm}^3$
- H  $0.0084 \text{ dm}^3$

- 58 The relative tendency for metals to form positive ions in solution can be measured using the following apparatus:

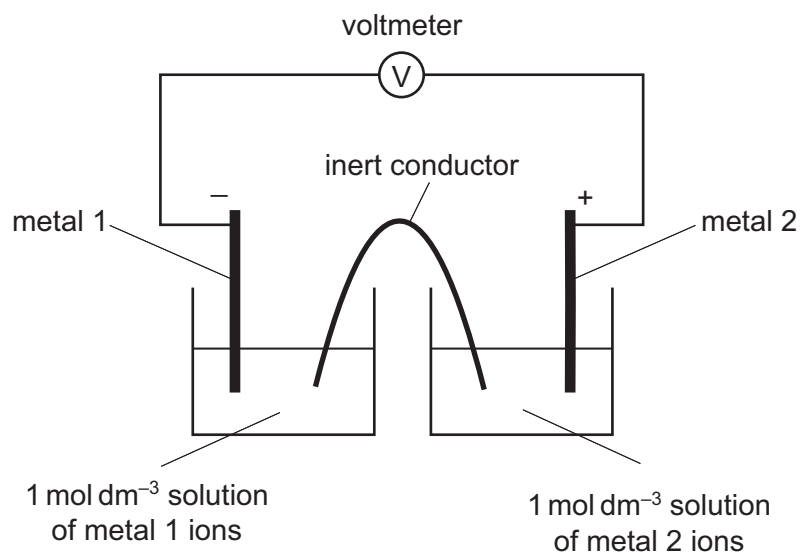

Electrons can pass from metal 1 to metal 2 via the external circuit. The difference in the tendency of the metals to form positive ions is given by the reading on the voltmeter. The higher the reading on the voltmeter the greater the **difference** in the tendency of the pair of metals to form positive ions.

Results from three experiments are given in the following table.

<i>experiment</i>	<i>metal 1</i>	<i>metal 2</i>	<i>reading on voltmeter / V</i>
1	P	Q	+0.62
2	S	Q	+0.30
3	S	R	+1.24

Using the information in the table, what is the order of reactivity of the four metals P, Q, R and S, from most reactive to least reactive?

- A P, Q, R, S
- B P, Q, S, R
- C P, S, Q, R
- D P, S, R, Q
- E S, P, Q, R
- F S, P, R, Q
- G S, R, Q, P
- H S, R, P, Q

- 59** A sample of aluminium ore (bauxite) contains 75.0% by mass of hydrated aluminium oxide. Hydrated aluminium oxide is one mole of aluminium oxide combined with two moles of water. What is the minimum mass of this sample of bauxite that is required to produce 108 tonnes of aluminium?

(1 tonne =  $1 \times 10^6$  g.  $A_r$  values: H = 1; O = 16; Al = 27)

- A** 184 tonnes
  - B** 207 tonnes
  - C** 272 tonnes
  - D** 276 tonnes
  - E** 368 tonnes
  - F** 421 tonnes
  - G** 592 tonnes
  - H** 736 tonnes
- 60** Equal amounts of carbon dioxide and carbon monoxide are produced when 2.0 mol of propanol,  $C_3H_7OH$ , are reacted with a limited supply of oxygen. Water is the only other product in this reaction.

How many moles of oxygen molecules are used in this reaction?

- A** 3.5 mol
- B** 7.0 mol
- C** 7.5 mol
- D** 8.5 mol
- E** 15 mol
- F** 17 mol

**PART D Biology**



- 61** Ambrosia beetles carry fungal spores from tree to tree. The beetles make holes in the branches of trees and create a network of tunnels in the wood. The fungus grows along the walls of the tunnels providing the only food source for the beetles. The fungus can penetrate xylem vessels and block them, which eventually kills the tree.

Which option correctly describes the relationship between these organisms?

- A** The beetle and the fungus have a mutualistic relationship.
- B** The beetle and the tree have a mutualistic relationship.
- C** The fungus is a parasite on the beetle.
- D** The fungus is the primary producer that the beetle feeds on.
- E** The tree is the primary producer that the beetle feeds on.

62 Which of the following graphs could describe processes taking place in the leaf of an oak tree in the presence of light?

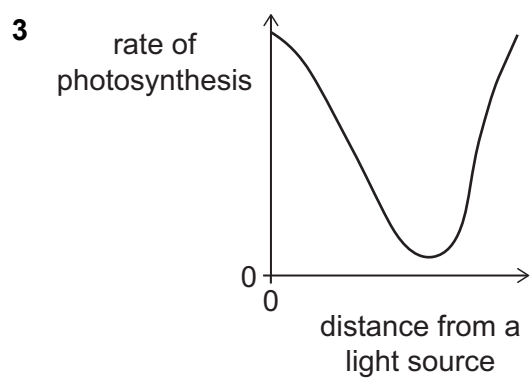
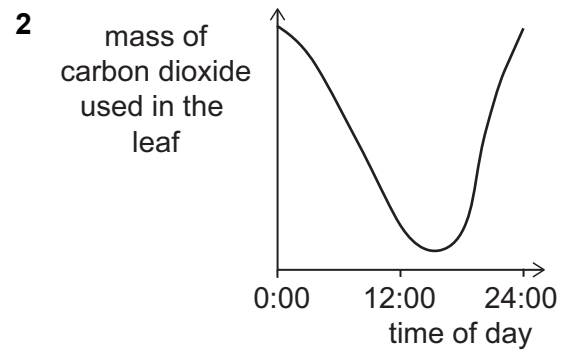
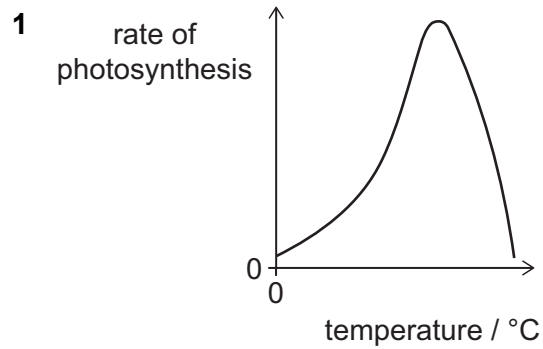

- A none of them
- B 1 only
- C 2 only
- D 3 only
- E 1 and 2 only
- F 1 and 3 only
- G 2 and 3 only
- H 1, 2 and 3

- 63 The diagram shows the flow of energy in a year's growth of grass from 1 m<sup>2</sup> of grassland.

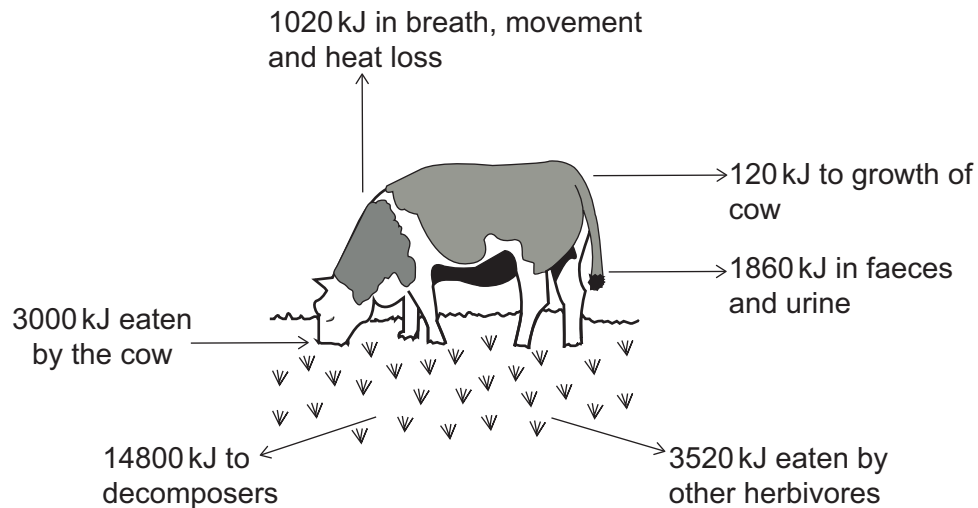

Which of the following statements is/are correct?

- 1 62% of the energy consumed by the cow is lost in faeces and urine.
  - 2 The diagram illustrates all the main processes of carbon uptake and release in the carbon cycle.
  - 3 4% of the energy absorbed by the cells of the cow is used for growth.
- A** none of them
- B** 1 only
- C** 2 only
- D** 3 only
- E** 1 and 2 only
- F** 1 and 3 only
- G** 2 and 3 only
- H** 1, 2 and 3

- 64** A Petri dish was filled with agar that had been mixed with starch. The agar is not digested by enzymes used in the experiment.

Four small wells were cut in the agar. Three were filled with different solutions. Well Y was filled with water to act as a control.

The dish was kept at 30 °C for 30 minutes. The surface of the agar was then washed with iodine solution, turning parts of it blue-black in the presence of starch.

The Petri dish was placed on a piece of graph paper, as shown in the diagram, to measure the clear areas around the wells. The area of each well should be considered negligible.

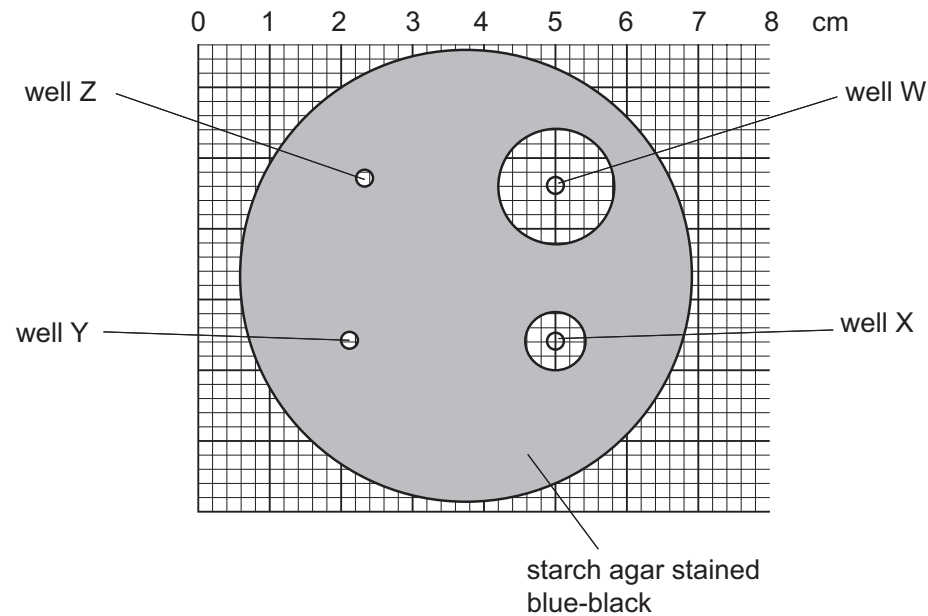

Which of the statements is/are correct?

- 1 The area of starch digested around well W is 4 times the area digested around well X.
  - 2 Amylase could have been used in well W and protease could have been used in well X.
  - 3 The solution put in well Z could have contained boiled enzyme.
- A** none of them
- B** 1 only
- C** 2 only
- D** 3 only
- E** 1 and 2 only
- F** 1 and 3 only
- G** 2 and 3 only
- H** 1, 2 and 3

- 65 The diagram shows a bubble potometer at the start of an experiment.

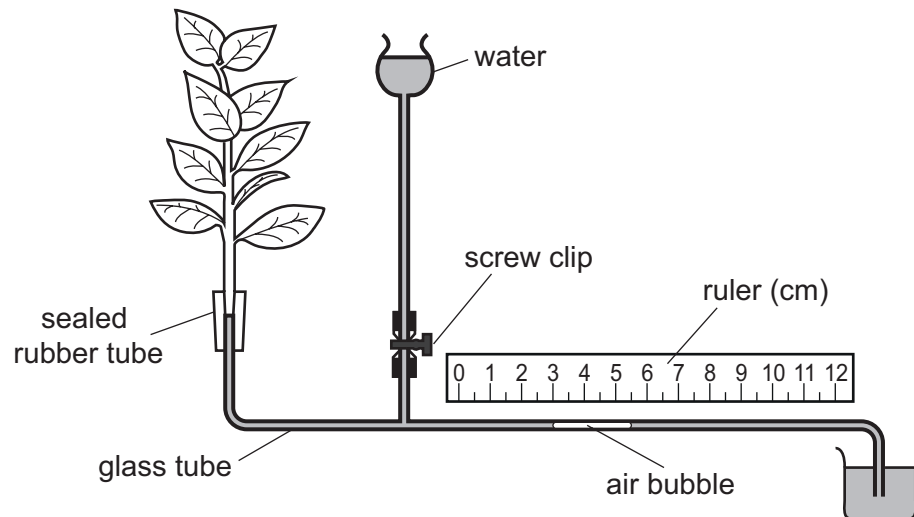

The glass tube has an internal diameter of 1 mm.

After five minutes, one end of the air bubble had moved to the 4 cm mark on the scale.

Which row is correct?

	<i>name of process being investigated</i>	<i>volume of water taken up / mm<sup>3</sup></i>
<b>A</b>	translocation	$\pi \times (0.5)^2 \times 10$
<b>B</b>	translocation	$\pi \times (0.5)^2 \times 15$
<b>C</b>	translocation	$2\pi \times (0.5) \times 10$
<b>D</b>	translocation	$2\pi \times (0.5) \times 15$
<b>E</b>	transpiration	$\pi \times (0.5)^2 \times 10$
<b>F</b>	transpiration	$\pi \times (0.5)^2 \times 15$
<b>G</b>	transpiration	$2\pi \times (0.5) \times 10$
<b>H</b>	transpiration	$2\pi \times (0.5) \times 15$

- 66** A chemical was added to a cell dividing by mitosis. This chemical binds to molecules, preventing the separation of the replicated chromosomes.

Using this information, which of the following effects could this chemical have on this cell division?

- 1** The four daughter cells contain double the normal number of chromosomes.
  - 2** The gametes contain the haploid number of chromosomes.
  - 3** The cell does not divide and contains the diploid number of replicated chromosomes.
- A** none of them
- B** 1 only
- C** 2 only
- D** 3 only
- E** 1 and 2 only
- F** 1 and 3 only
- G** 2 and 3 only
- H** 1, 2 and 3

- 67 A student viewed a bacterial cell using a microscope. The cell was measured with a microscope ruler as shown in the diagram. Each division on this ruler measures  $2.5\ \mu\text{m}$ .

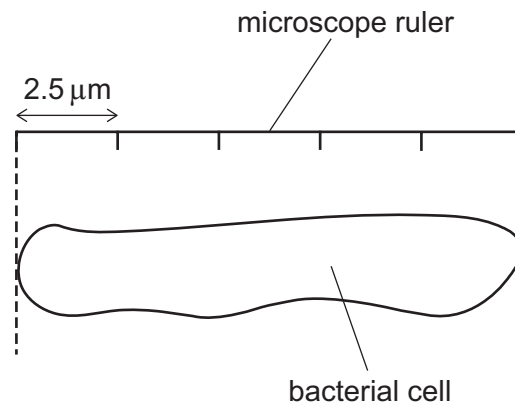

The student made a drawing of this cell. The drawing was 5.0 cm in length and included the structures that the student expected to see.

Which row of the table gives the magnification of the student's drawing and one of the structures that should be included?

	<i>magnification of the student's drawing</i>	<i>structure that should be included</i>
<b>A</b>	$2.5 \times 10^{-4}$	cell wall
<b>B</b>	$2.5 \times 10^{-4}$	nucleus
<b>C</b>	$4.0 \times 10^{-1}$	cell wall
<b>D</b>	$4.0 \times 10^{-1}$	nucleus
<b>E</b>	$4.0 \times 10^3$	cell wall
<b>F</b>	$4.0 \times 10^3$	nucleus
<b>G</b>	$2.0 \times 10^4$	cell wall
<b>H</b>	$2.0 \times 10^4$	nucleus

- 68** The table shows details of genetic characteristics of three species of organisms and the genetic crosses carried out with them.

<i>cross</i>	<i>organism</i>	<i>dominant characteristic</i>	<i>recessive characteristic</i>	<i>description of parents in cross</i>	
V	cattle	have horns	hornless	heterozygous horned	× hornless
W	fruit flies	grey-bodied	ebony-bodied	heterozygous grey-bodied	× heterozygous grey-bodied
Y	pea plants	round seeds	wrinkled seeds	wrinkled seeds	× homozygous round seeds

All alleles exhibit simple dominant/recessive relationships.

Which of the following statements is/are correct?

- 1** If two of the offspring from cross V are bred together, three different crosses could result, with three different probabilities of phenotypes in the next generation: 100% hornless, 50% hornless, or 25% hornless.
  - 2** The genotypes of the offspring with the dominant characteristic from cross W will be identifiable through their phenotypes.
  - 3** A farmer planted seeds collected from the offspring of cross Y. If these seeds grew and produced flowers which were then cross-pollinated with each other, the resulting seeds would yield a crop containing 50% homozygous plants.
- A** none of them
- B** 1 only
- C** 2 only
- D** 3 only
- E** 1 and 2 only
- F** 1 and 3 only
- G** 2 and 3 only
- H** 1, 2 and 3



- 69** The table shows the relationship between heart rate and blood output from the left ventricle of a healthy human heart.

<i>heart rate in beats per minute</i>	55	70	80	90	120	140	150	175
<i>blood output in dm<sup>3</sup> from the left ventricle of the heart each minute</i>	4.0	5.0	5.2	5.6	6.0	6.0	5.8	4.6

Which of the following statements is/are correct?

- 1** The volume of blood pumped out of the heart each minute is directly proportional to the heart rate.
  - 2** When the heart rate increased from 55 to 70 beats per minute, the blood output from the heart increased by 20%.
  - 3** Blood output from the heart to the lungs will be less than that to the rest of the body.
- A** none of them
- B** 1 only
- C** 2 only
- D** 3 only
- E** 1 and 2 only
- F** 1 and 3 only
- G** 2 and 3 only
- H** 1, 2 and 3

- 70 The diagram shows a flow chart representing the hormonal activity associated with the menstrual cycle.

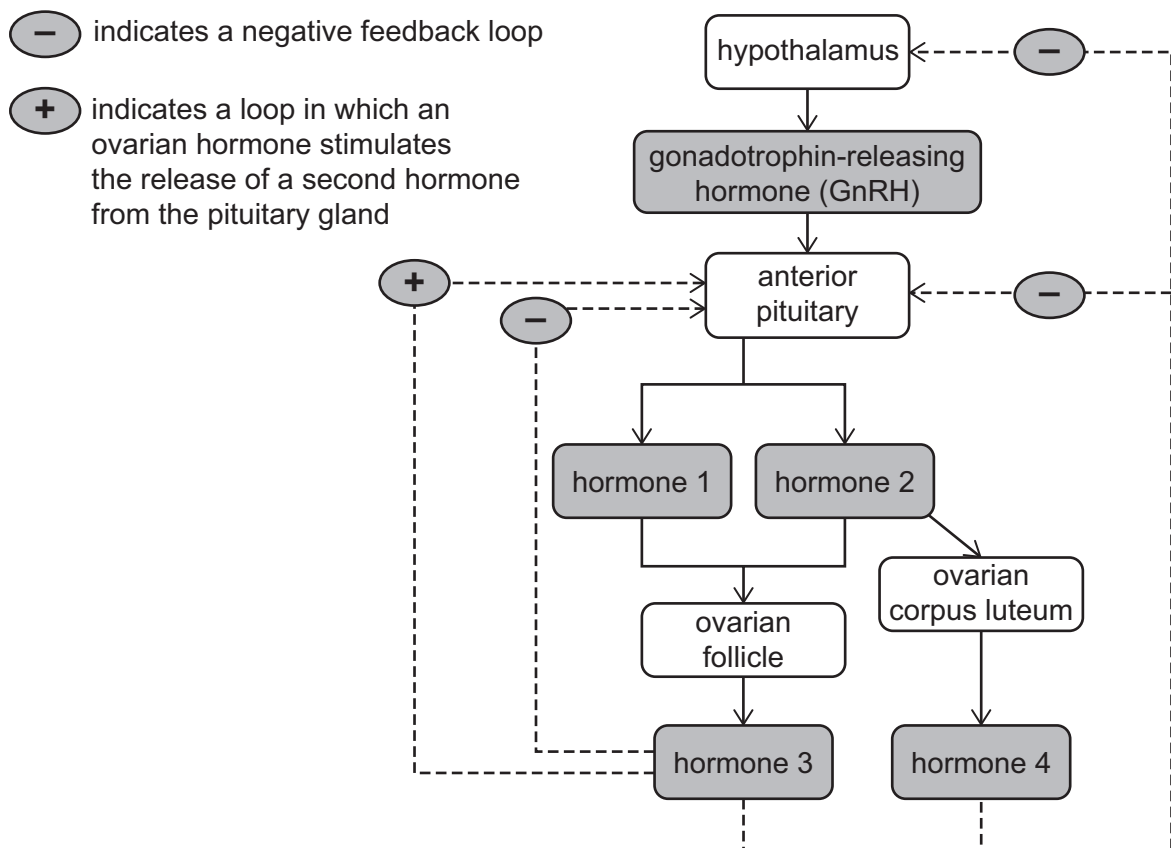

Which of the following statements about the menstrual cycle is/are correct?

- 1 Hormone 1 stimulates follicle maturation and the release of hormone 3 from the ovarian follicle.
  - 2 Hormone 4 maintains the uterus lining.
  - 3 At the end of the menstrual cycle the levels of hormone 1 and hormone 2 will reach their highest point and then decrease, leading to menstruation.
- A** none of them  
**B** 1 only  
**C** 2 only  
**D** 3 only  
**E** 1 and 2 only  
**F** 1 and 3 only  
**G** 2 and 3 only  
**H** 1, 2 and 3

71 A scientist was investigating the effect of substrate concentration on lipase enzyme activity

Two test tubes were set up:

- one containing a sample of full-fat milk mixed with an alkaline solution, and a pH indicator
- one containing lipase

The pH indicator turned the alkaline milk sample pink.

Both tubes were incubated in a water bath set to an optimum temperature for lipase until the contents had reached this temperature.

The scientist then added the lipase to the tube with the milk sample and measured the time taken for the indicator to turn colourless. This colour change was caused by an increase in concentration of one of the products of the reaction.

Further samples of the milk were diluted, and added to the same quantity of alkaline solution and pH indicator, to produce another six different substrate concentrations, and the experiment was repeated. All other variables were kept constant.

The scientist found that each substrate concentration caused the pH indicator to change to colourless in a different length of time. The results of the reaction in all seven tubes were plotted on a graph.

Which option correctly identifies the shape of the graph of the results, the limiting factor during the experiment and an explanation for the change in colour of the pH indicator?

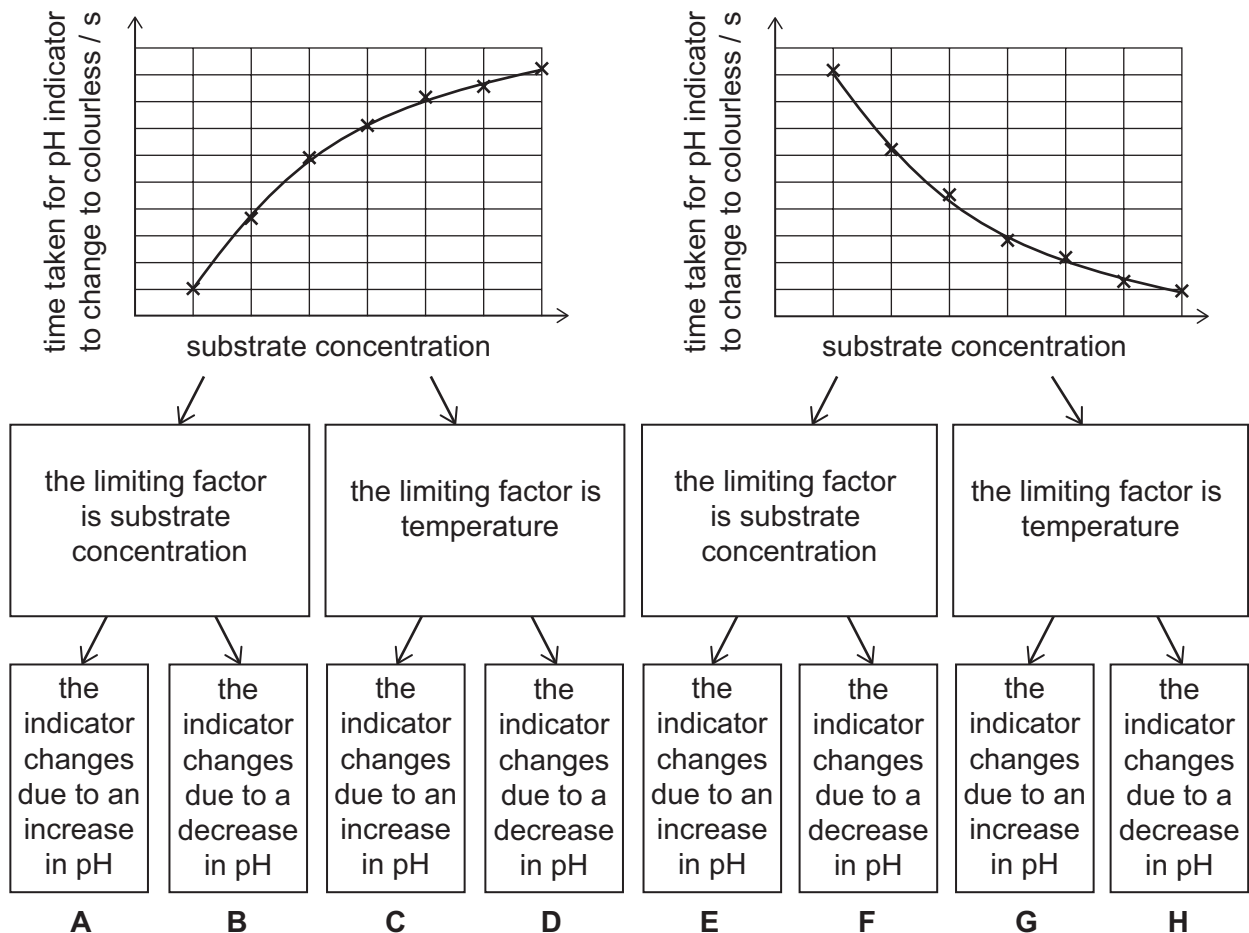

- 72** Even when sufficient oxygen is available, yeast will respire anaerobically using glucose as a substrate. However, if its source of glucose runs out and oxygen is available, yeast can switch to using ethanol as a substrate, which it uses to respire aerobically.

A sample of yeast was added to 100 cm<sup>3</sup> glucose solution in an open flask.

The contents of the flask were monitored over 32 hours and the results are shown in the graph.

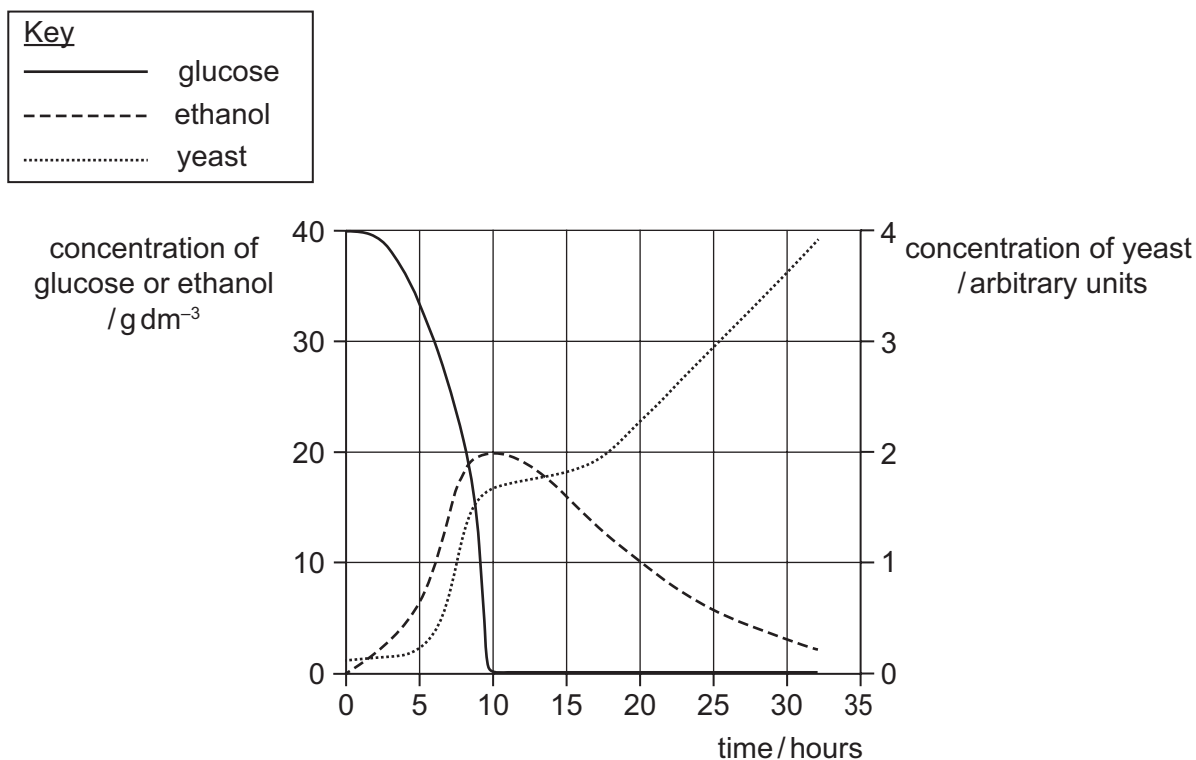

Which of the following statements are correct?

- 1 Carbon dioxide would be produced in the flask at all times throughout the observation period, regardless of whether the yeast was respiring aerobically or anaerobically.
  - 2 The yeast was respiring using ethanol as the only substrate for 22 hours.
  - 3 The yeast started respiring anaerobically from the start of the observation period.
  - 4 The yeast used an average of 4 g glucose per hour for the first 10 hours.
- A** 1, 2 and 3 only
- B** 1, 2 and 4 only
- C** 1, 3 and 4 only
- D** 2, 3 and 4 only
- E** 1, 2, 3 and 4

73 The diagram represents part of the carbon cycle.

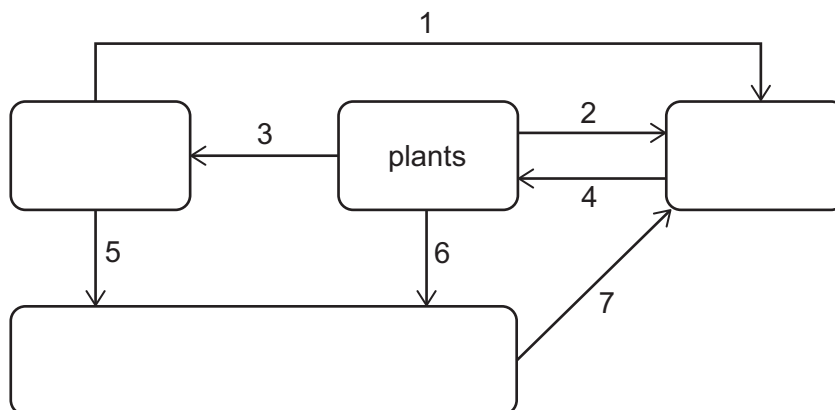

Which of the arrows represent processes resulting in at least one organic product (contains carbon and hydrogen)?

- A 3 only
- B 4 only
- C 5 and 6 only
- D 1, 2 and 7 only
- E 3, 5 and 6 only
- F 1, 2, 3 and 4 only
- G 3, 4, 5 and 6 only
- H 1, 2, 3, 4, 5, 6 and 7

- 74 In an experiment, 8 identical cubes of potato were each weighed and placed in a different test tube.

Each of the test tubes contained a different concentration of sodium chloride solution. All other conditions were kept the same throughout the experiment.

After 30 minutes, the potato cubes were removed from the test tubes and weighed, and the percentage change in mass was calculated.

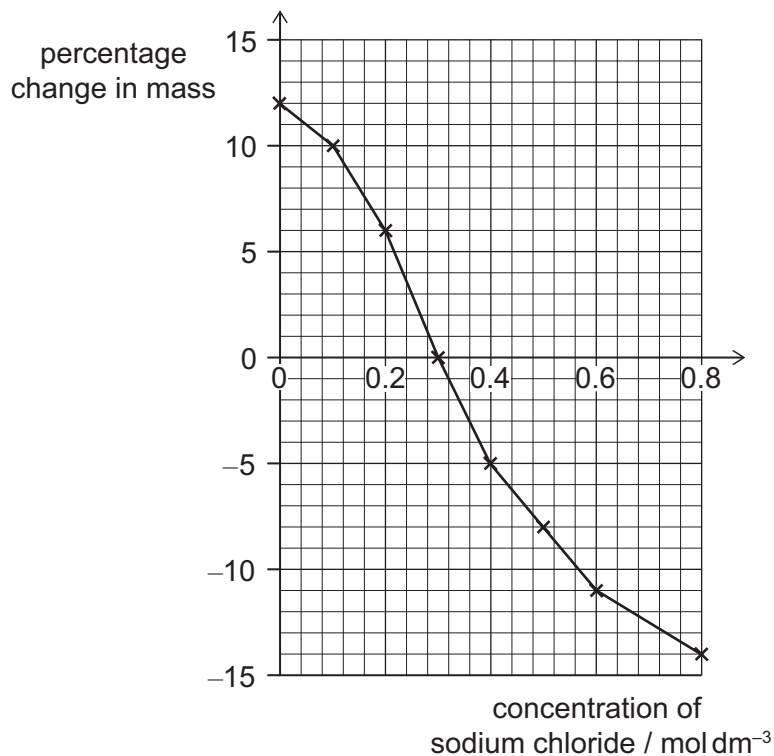

Which of the following statements is/are correct?

- 1 The initial concentration of sodium chloride inside the potato cubes must be  $0.3 \text{ mol dm}^{-3}$ .
  - 2 Osmosis involves the diffusion of water molecules from a solution of high solute concentration to one of low solute concentration.
  - 3 In this experiment, the rate of osmosis is fastest at a sodium chloride concentration of  $0.8 \text{ mol dm}^{-3}$ .
- A none of them
- B 1 only
- C 2 only
- D 3 only
- E 1 and 2 only
- F 1 and 3 only
- G 2 and 3 only
- H 1, 2 and 3

- 75** The same section of a gene was taken from two different people and the DNA sequenced to show the triplets on one strand.

The results for each person are shown.

<i>person 1</i>	TCC	GCG	AGC	CCC	TTG	AGG
<i>person 2</i>	TCC	GCG	AGC	CCG	TTA	AGG

Which of the following statements about the sequences could be correct?

- 1** Person 2 has one mutation in the section of the gene.
  - 2** Both people have the same phenotype for this gene.
  - 3** This section of the gene codes for up to 6 bases.
- A** none of them
- B** 1 only
- C** 2 only
- D** 3 only
- E** 1 and 2 only
- F** 1 and 3 only
- G** 2 and 3 only
- H** 1, 2 and 3

- 76 The family tree shows the inheritance of an autosomal recessive genetic condition.

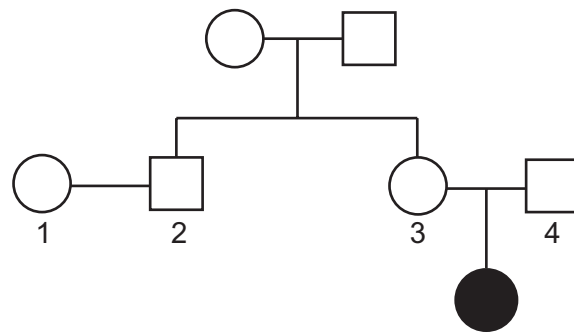
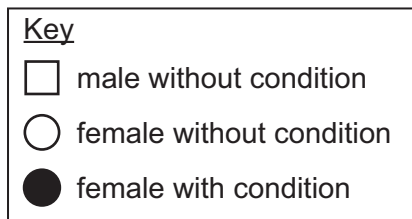

Which of the following statements is/are correct for this family?

- 1 If one cheek cell is collected from each individual, the overall ratio of X chromosomes to Y chromosomes will be 3.67 : 1
- 2 The probability of individual 2 and individual 3 having the same alleles on their X chromosomes is 100%.
- 3 The probability of individual 2 and individual 3 having the same genotype for the condition is 50%.

(Assume no mutations.)

- A none of them
- B 1 only
- C 2 only
- D 3 only
- E 1 and 2 only
- F 1 and 3 only
- G 2 and 3 only
- H 1, 2 and 3



**77** The sugar present in DNA contains 5 carbons.

A section of single-stranded DNA contains five different triplets.

Which of the following statements about this strand could be correct?

- 1** There are 75 carbons in the sugar–phosphate backbone in this section.
  - 2** The minimum number of different bases present in the base sequence is 2.
  - 3** The number of sugar-to-phosphate bonds is equal to the number of nucleotides.
- A** none of them
- B** 1 only
- C** 2 only
- D** 3 only
- E** 1 and 2 only
- F** 1 and 3 only
- G** 2 and 3 only
- H** 1, 2 and 3

- 78 The graph shows the change in the pressure in the space X between the wall of the thorax and the lungs (as shown in the diagram) during one complete breathing cycle.

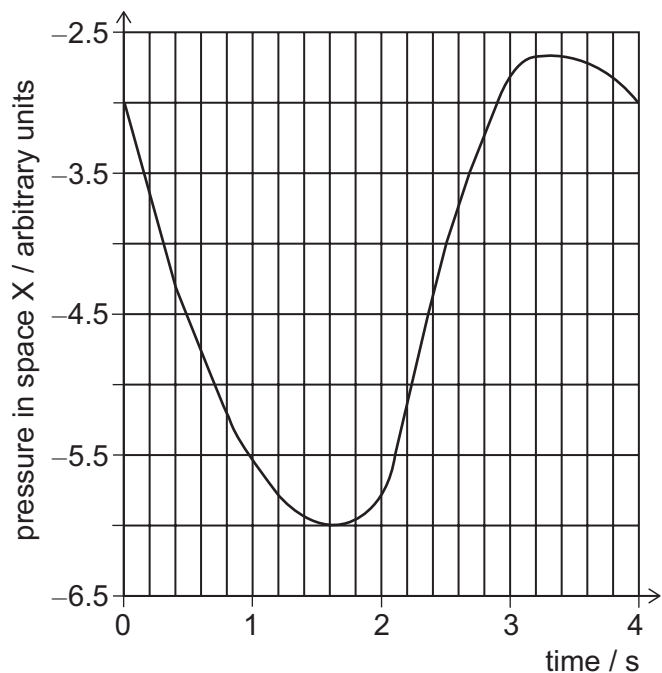
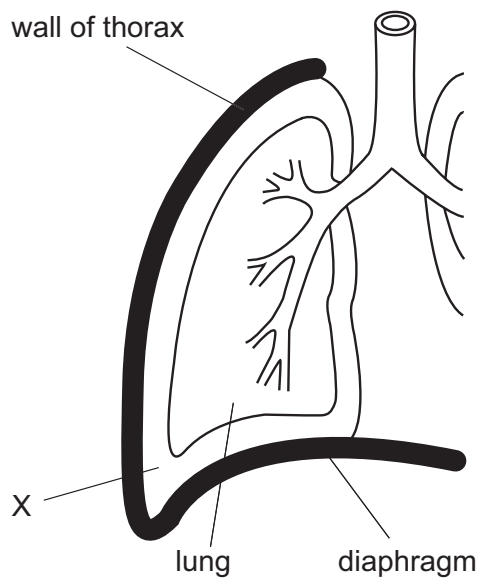

Which of the following statements is/are correct?

- 1 The person is breathing out between 0 and 1.5 seconds.
- 2 The diaphragm is relaxing between 2 and 3 seconds.
- 3 The rate of breathing is 15 breaths per minute.

(Assume the person continues breathing at the same rate.)

- A none of them
- B 1 only
- C 2 only
- D 3 only
- E 1 and 2 only
- F 1 and 3 only
- G 2 and 3 only
- H 1, 2 and 3

- 79** In a mammal, an impulse travels along a neurone of length 45 cm in  $3.0 \times 10^{-3}$  seconds.

Transmission across the synapse to another neurone takes  $4.0 \times 10^{-10}$  seconds. The synapse has a width of 20 nm.

Which row correctly compares the speed of transmission across the synapse with the speed of transmission along the neurone, and what is the method of transmission across the synapse?

	<i>speed of transmission across the synapse compared to speed of transmission along the neurone</i>	<i>method of transmission across the synapse</i>
<b>A</b>	300 times faster	chemical, by active transport
<b>B</b>	300 times faster	chemical, by diffusion
<b>C</b>	300 times faster	electrical impulse
<b>D</b>	3 times slower	chemical, by active transport
<b>E</b>	3 times slower	chemical, by diffusion
<b>F</b>	3 times slower	electrical impulse
<b>G</b>	300 times slower	chemical, by diffusion
<b>H</b>	300 times slower	electrical impulse

- 80** Four blood cells were taken from a human:

- one that was about to start cytokinesis
- one actively producing antibodies
- two that cannot use oxygen for respiration

What is the total number of chromosomes present in all of the cells mentioned above?

(Ignore mitochondrial DNA.)

- A** 92  
**B** 115  
**C** 138  
**D** 161  
**E** 184  
**F** 207



**Cambridge Assessment**  
Admissions Testing